

INSTALLATION INSTRUCTIONS

1. ENSURE THE APERTURE IS CLEAN AND FREE OF DUST AND DEBRIS.
2. THE CABLES SHOULD BE TIGHTLY BUNDLED TOGETHER.
3. APPLY A NOMINAL 5MM BEAD OF RYANFIRE MASTIC INTO THE ANNULAR GAP BETWEEN THE BUNDLE AND THE WALL.
4. SELECT THE CORRECT SIZE RYANFIRE SL COLLAR TO FIT AROUND THE CABLE BUNDLE.
5. SECURE THE SL COLLAR AROUND THE BUNDLE AND SLIDE IT AGAINST THE SURFACE OF THE WALL. FIX THE COLLAR INTO THE WALL WITH 12G X 30MM TEK SCREWS.
6. APPLY HP-X INTO THE ANNULAR GAP BETWEEN THE BUNDLE AND THE SL COLLAR, TO THE FULL DEPTH OF THE SL COLLAR.
7. WRAP 1 LAYER OF 300MM WIDE SERVOWRAP TIGHTLY AROUND THE BUNDLE, WITH A MINIMUM 100MM OVERLAP ON THE LONG EDGE. SLIDE THE SERVOWRAP AGAINST THE COLLAR.
8. SECURE THE SERVOWRAP AROUND THE CABLES USING STEEL CABLE TIES 50MM FROM EACH END AND 1 NOMINALLY IN THE CENTRE.
9. SEAL ANY EXPOSED EDGES OF THE SERVOWRAP WITH FOIL TAPE.
10. REPEAT THIS PROCESS ON THE OPPOSITE SIDE OF THE WALL.

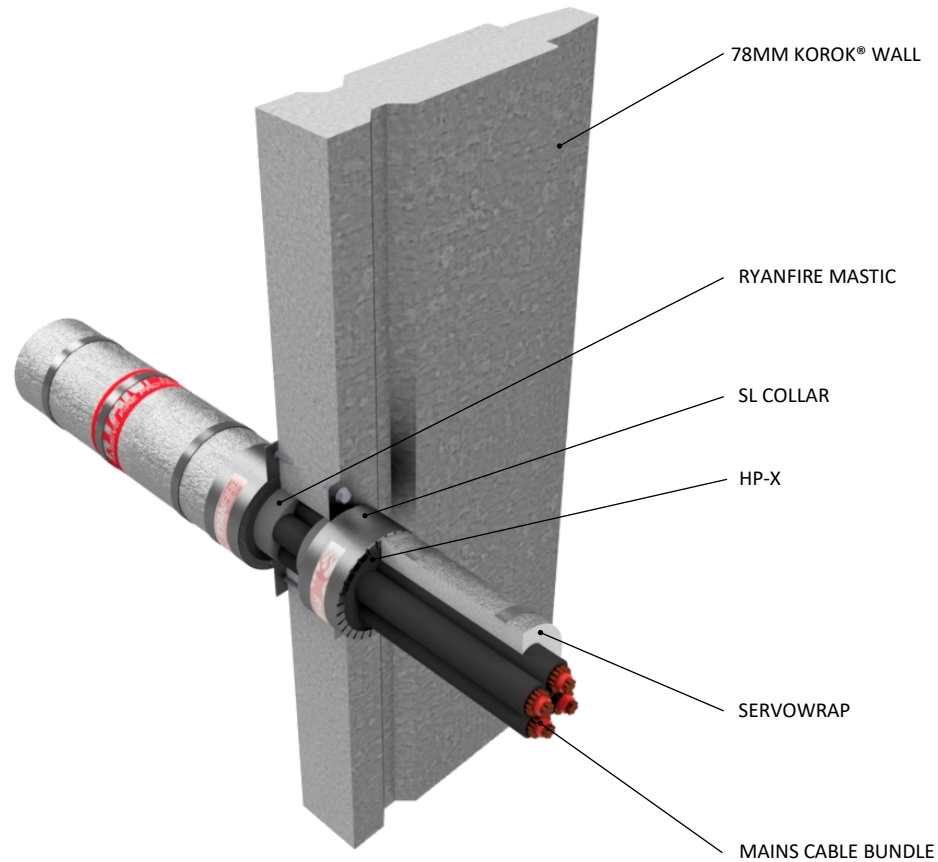

Products:	RYANFIRE SL COLLAR RYANFIRE HP-X RYANFIRE SERVOWRAP RYANFIRE MASTIC
Approvals:	AS 1530.4:2014/AS 4072.1:2005
BK:	357
Ref:	255FR00064
ID:	I
Scenario:	Penetration seal to mains cable bundle
Services:	Up to 4 x 25mm ² mains cables
Aperture:	Max Ø53mm
Construction:	78mm KOROK® wall
Fire Integrity:	120 minutes
Fire Insulation:	90 minutes

Web based drawings are for example only. Fire performance of any system is dependant on, but not limited to size of opening, substrate, if penetrations are passing through, type, size and number. Please refer to Ryanfire technical department for detailed and specific fire performance information.



RYANFIRE Technical Support:
info@ryanfire.co.nz - Tel 09 443 0362

Drawing Title
**SL Collar, HP-X & Servowrap to mains bundle
78mm KOROK® wall**

Scale	NTS	Date	June 2026
Drawing Number	V36.23	Rev	1.0

All errors and omissions excepted. The information contained within this drawing is believed to be correct on the date of publication, and is based upon tested and certified solutions. The policy of Ryanfire Products is one of constant improvement. Installers must ensure that they are following the latest published drawings, test evidence and instructions. Whilst Ryanfire Products will endeavour to keep its publications up to date, the accuracy of the information contained within this drawing may be affected by pertinent changes in the law or regulatory requirements and alterations or amendments to the specification of the manufactured products. Terms and conditions of sale apply.

Ryanfire Products owns and has copyright to these drawings. They are to be used only for the purpose for which they were intended and supplied and are not to be sold, transferred or made available for use by a third party. Any misuse of these drawings will result in legal proceedings.