

INSTALLATION INSTRUCTIONS

1. ENSURE THE APERTURE IS CLEAN AND FREE OF DUST AND DEBRIS.
2. APPLY A BEAD OF RYANFIRE MASTIC INTO THE ANNULAR GAP BETWEEN THE COPPER PIPE AND THE FLOOR.
3. WRAP 1000MM WIDE RYANFIRE ROKWRAP TIGHTLY AROUND THE PIPE WITH A 100MM OVERLAP.
4. SECURE THE ROKWRAP INTO PLACE WITH STAINLESS STEEL CABLE TIES, 50MM FROM EACH END AND AT MINIMUM 150MM CENTRES.
5. APPLY A 50MM X 50MM RYANFIRE MASTIC CONE TO THE JUNCTION BETWEEN THE ROKWRAP AND THE FLOOR.
6. REMOVE EXCESS MASTIC WITH A DAMP CLOTH.

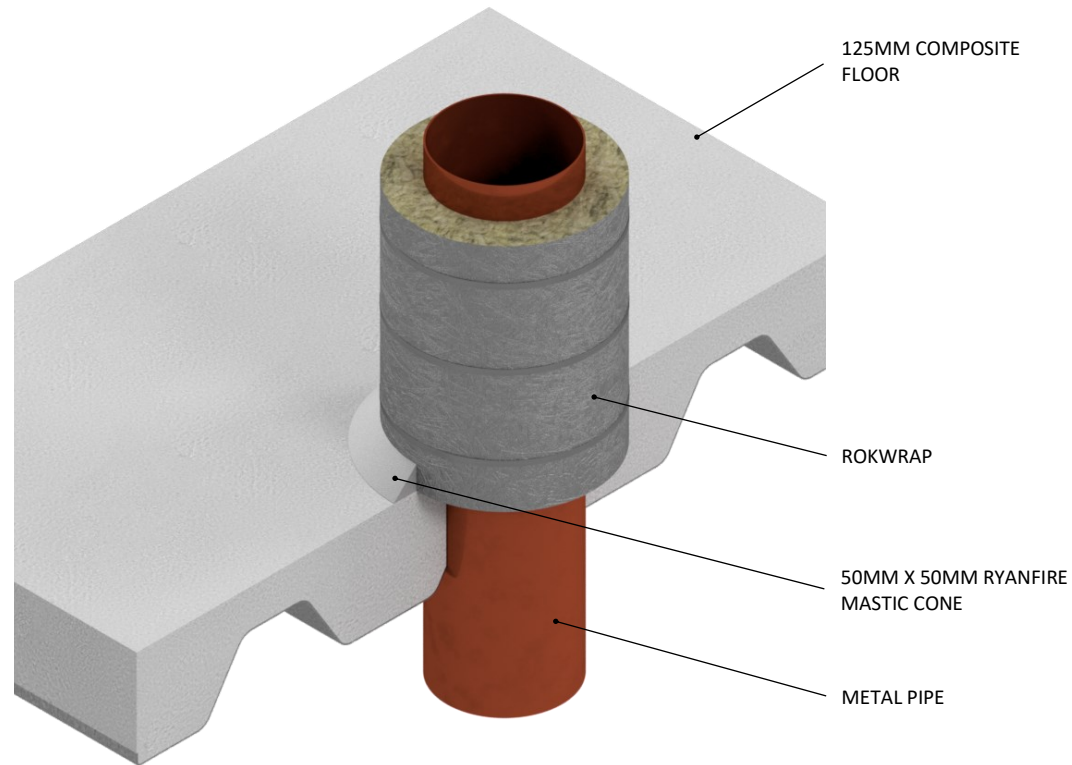

Products:	RYANFIRE MASTIC RYANFIRE ROKWRAP
Approval:	AS 1530.4/4072.1
BK:	103
Ref:	21SFR00047
ID:	D
Scenario:	Penetration seal to copper /steel pipe
Services:	Ø150mm copper / steel pipe
Annular:	3mm
Construction:	125mm thick composite floor
Fire Integrity:	90 minutes
Fire Insulation:	60 minutes

Web based drawings are for example only. Fire performance of any system is dependant on, but not limited to size of opening, substrate, if penetrations are passing through, type, size and number. Please refer to Ryanfire technical department for detailed and specific fire performance information.



Client
Job Title
Drawing Title
Ryanfire Rokwrap to metal pipes 125mm composite floor

Please note:
Ryanfire Products owns and has copyright in these drawings. They are to be used only for the purpose for which they were intended and supplied and are not to be sold, transferred or made available for use by a third party.

Any misuse of these drawings will result in legal proceedings.

All errors and omissions excepted - the Information contained within this drawing is believed to be correct on the date of publication, and is based upon tested and certified solutions. The policy of **RyanFire Products** is one of constant improvement. Installers must therefore ensure that they are following the latest published drawings, test evidence and instructions. Whilst **RyanFire Products** will endeavour to keep its publications up to date, the accuracy of the information contained within this drawing may be affected by pertinent changes in the law or regulatory requirements and alterations or amendments to the specification of the **manufactured** products. Terms and conditions of sale apply.

RYANFIRE Technical Support: info@ryanfire.co.nz - Tel 09 443 0362

Scale	NTS	Date	July 2024
Sheet Size	A3	Drawn By	
Drawing Number	V3.3	Rev	2.0